



Code of Practice

on Access for External Maintenance

2021



FOREWORD

Buildings need regular maintenance and repair (M&R) to prevent them from rapid deterioration. The maintainability concept should therefore be integrated in the building design so as to facilitate M&R. Provision of adequate means of access for maintenance of the external building elements of a building (i.e. maintenance and repair access (M&R access)) in building design is of paramount importance in the maintainability strategy.

With the coming into operation of the Building (Construction) Regulation (Cap. 123Q) (B(C)R) on 1 February 2021, sections 27(2), 28(5), 31(3) and 34(3) of the B(C)R require the provision of adequate M&R access to the outer surface of external walls, claddings, curtain walls and roofs of a building or projections from the external walls, claddings, curtain walls and roofs. Compliance with the provisions of the Code of Practice on Access for External Maintenance 2021 (the Code) will be deemed to satisfy these statutory requirements. In this connection, the Code supersedes the advisory Code of Practice on Design for Safety – External Maintenance 2019 (Previous Code) promulgated in September 2019.

It is strongly recommended that in addition to the provision of M&R access for meeting the statutory requirements under B(C)R, the safety requirements for work-at-height under the Occupational Safety and Health Ordinance (Cap. 509) (OSHO), the Factories and Industrial Undertakings Ordinance (Cap. 59) (FIUO) and their subsidiary regulations should be holistically addressed at the design stage of a building. The Code will not override or replace any legal rights, responsibilities or regulatory requirements under the OSHO and FIUO.

The Code will be reviewed regularly. As such, a technical committee comprising representatives of professional institutions and other stakeholders of the building industry as well as relevant government departments has been established for collecting views and feedback on the use of the Previous Code¹ and the Code from the building industry and practitioners and keeping the Code abreast with the advancements in design, technologies and construction practices. BD welcomes suggestions for improving the Code.

Buildings Department
February 2021

¹ Taking into account the advice of the technical committee, the Code has incorporated amendments to the Previous Code, the details of which are given in PNAP APP-163.

TABLE OF CONTENTS

	Page
PART 1 - GENERAL	
1. Scope	1
2. Interpretations	1
3. Reference	3
PART 2 - PROVISION OF MEANS OF EXTERNAL MAINTENANCE ACCESS	
1. General	4
2. External Wall, Curtain Wall and External Cladding	4
3. Projection from External Wall, Curtain Wall or External Cladding	4
3.1. Air-conditioner platform	4
3.2. Balcony and utility platform	5
3.3. Canopy	5
3.4. Drying rack	5
3.5. External drainage pipe	5
3.6. External vertical greenery	6
3.7. Planter box	6
3.8. Projecting window	6
3.9. Signboard	6
3.10. Sun-shade, reflector, eave, cornice, moulding, overhang, fin and other architectural projection	7
4. Roof	7
4.1 Accessible roof	7
4.2 Inaccessible roof	8
5. Projection from a Roof	8
PART 3 - DESIGN AND CONSTRUCTION REQUIREMENTS	
1. General Requirements	9
2. Specific Requirements	10
2.1. Suspended working platform	10
2.2. Maintenance access window	11
2.3. Maintenance staircase	11
2.4. Maintenance door	11
2.5. Fixed maintenance ladder or external walkway	12

2.6.	Maintenance access ladder and gantry system	12
2.7.	Power-operated elevating work platform	12
3.	Checklist and Submission of M&R Access Plans	12
APPENDIX A	Reference	13
APPENDIX B	Requirements of air-conditioner platform combined with a balcony/utility platform	15
APPENDIX C	Requirements of design and safety provisions for the air-conditioner platform	18
APPENDIX D	Statutory occupational safety requirements	22
APPENDIX E	Checklist for provision of maintenance and repair access	25
APPENDIX F	Procedures for Submission of Maintenance & Repair Access Plans for Compliance with Code of Practice on Access for External Maintenance	27
APPENDIX G	Example of cast-in anchor	30

PART 1 - GENERAL

1. Scope

The Code of Practice on Access for External Maintenance (the Code) sets out the guidelines for providing means of access for maintenance to the external wall, curtain wall, external cladding, roof and projection of a building.

2. Interpretations

“Direct staircase” means a staircase providing access to an accessible roof.

“External building element” means external wall, curtain wall, external cladding or roof of a building and the projection from the external wall, curtain wall, external cladding or roof.

“External wall” includes the whole, or any part, of the external wall of a building.

“Fixed maintenance ladder or external walkway”² means a metal cat ladder or maintenance walkway.

“Maintenance” means maintenance and repair (M&R) works which include inspection, routine cleansing, repair and replacement of defective external building elements and their components.

“Maintenance access ladder and gantry system”³ is a means of external maintenance access with gantries travelling along the tracks affixed onto a building, that is specially designed to fit the building profile having inclined facade, dome-shaped roof, skylights or other building features.

“Maintenance access window”⁴ means an openable window for maintenance access.

² Paragraph 2.5 of Part 3 of the Code refers.

³ Paragraph 2.6 of Part 3 of the Code refers.

⁴ Paragraph 2.2 of Part 3 of the Code refers.

“Maintenance door”⁵ means a door for maintenance access.

“Means of access for maintenance” means any means of access providing safe access for maintenance and repair of the external building elements (M&R access). Common M&R access is provided in Part 3 of the Code.

“Power-operated elevating work platform”⁶ is also named as cherry pickers and aerial platforms, that can be vehicle-mounted, self-propelled, towed or manually-moved.

“Projection” includes projections under Part II of the Building (Planning) Regulations (Cap. 123F) (B(P)R), projections from a building stipulated under Practice Note for Authorized Persons, Registered Structural Engineers and Registered Geotechnical Engineers (PNAP) APP-19, signboards stipulated under section 2 of the Buildings Ordinance (Cap. 123) (BO), and other architectural projections. Examples include eave, cornice, moulding, overhang, fin, canopy, sun-shade, reflector, projecting window, balcony, utility platform, projecting planter box, drying rack, air-conditioner platform, external drainage pipe, supporting frame of vertical greenery and retractable awning.

“Projection from a roof” means any structures erected or installed on a roof such as architectural projection, water tank, gantry, lightning rod, signboard, supporting structure of solar energy system, etc.

“Roof” includes flat roof, main roof, upper roof, pitched roof, profiled roof, skylight, membrane roof, and the roof of a covered walkway or a footbridge.

⁵ Paragraph 2.4 of Part 3 of the Code refers.

⁶ Paragraph 2.7 of Part 3 of the Code refers.

“Suspended working platform (also named as gondola system)”⁷ has the same interpretation as assigned to it in the Factories and Industrial Undertakings (Suspended Working Platforms) Regulation (Cap. 59AC) which is reproduced below:

“means a scaffold (not being a slung scaffold) or a working platform suspended from a building or structure by means of lifting gear and capable of being raised or lowered by lifting appliances (but does not include a boatswain’s chair or similar device), and includes all lifting appliances, lifting gear, counterweights, ballast, outriggers, other supports and the whole of the mechanical and electrical apparatus required in connection with the operation and safety of such a scaffold or working platform.”

3. Reference

The Code has made reference to the legislation, codes of practice, design manuals, practice notes and guidelines set out in *Appendix A*.

⁷ Paragraph 2.1 of Part 3 of the Code refers.

PART 2 - PROVISION OF MEANS OF ACCESS FOR EXTERNAL MAINTENANCE

1. General

- 1.1 Suitable, adequate and safe M&R access shall be provided to the external walls, curtain walls, external claddings and roofs of a building and the projections from the external walls, curtain walls, external claddings and roofs (building projections) in the building design to enable workers' access to these external building elements for M&R safely.
- 1.2 The M&R access in this Part is not meant to be exhaustive. Depending on the building design and merits of individual projects, one type or a combination of various types of M&R access may be required
- 1.3 Attention shall be drawn to the design of building projection, building recess and free-form building profile to enable the erection of temporary scaffold in accordance with the Guidelines on the Design and Construction of Bamboo Scaffolds.

2. External Wall, Curtain Wall and External Cladding

- 2.1 The major M&R works for external wall, curtain wall and external cladding include inspection, cleansing, repair and replacement of defective building elements and components, such as wall finishes, windows, window walls, glass panes, cladding panels, etc.
- 2.2 The M&R access shall be provided by maintenance access window, maintenance door, power-operated elevating work platform or suspended working platform.

3. Projection from External Wall, Curtain Wall or External Cladding

3.1 *Air-conditioner (AC) platform*

- 3.1.1 The major M&R works for AC platform include inspection, cleansing, repair and replacement of AC, and maintenance of the platform.
- 3.1.2 The M&R access shall be provided by maintenance access window or balcony/utility platform (UP) combined with an AC platform. Such balcony/UP shall be designed in accordance with *Appendix B*.

- 3.1.3 The M&R access to the outer surface of AC platform shall be provided by power-operated elevating work platform or suspended working platform.
- 3.1.4 The AC platform may serve as the M&R access for other utilities and services provided that the working space required for M&R for AC will not be jeopardised.
- 3.1.5 All requirements of design and safety provisions for M&R access of AC platforms in *Appendix C* shall be followed.

3.2 *Balcony and UP*

- 3.2.1 The major M&R works for balcony and UP include inspection, cleansing and repair.
- 3.2.2 The M&R access shall be provided by maintenance access door.
- 3.2.3 The M&R access to the outer surface of balcony and UP shall be provided by power-operated elevating work platform or suspended working platform.

3.3 *Canopy*

- 3.3.1 The major M&R works for canopy include inspection, cleansing, removal of debris, and repair and replacement of defective part of the canopy and drainage outlet.
- 3.3.2 The M&R access shall be provided by power-operated elevating work platform, suspended working platform, or maintenance access window.

3.4 *Drying rack*

- 3.4.1 The major M&R works for drying rack include cleansing, repair and replacement of the defective part.
- 3.4.2 The M&R access shall be provided by maintenance access window, maintenance access door, power-operated elevating work platform or suspended working platform.

3.5 *External drainage pipe*

- 3.5.1 The major M&R works for external drainage pipe include inspection, repair and replacement of the defective drainage pipes.

3.5.2 The M&R access shall be provided by cat ladder with grating platform in pipe well complying with PNAP APP-93, projecting platform such as AC platform, maintenance access window, power-operated elevating work platform or suspended working platform.

3.5.3 The planning and design of M&R access to drainage works for a new building shall comply with the requirements stipulated in PNAP APP-93.

3.6 *External vertical greenery*

3.6.1 The major M&R works for external vertical greenery include inspection, general gardening, and repair of the drainage point, irrigation/drainage pipework and supporting frame for the greenery.

3.6.2 The M&R access shall be provided by power-operated elevating work platform, suspended working platform, or fixed walkway accessible from the interior of a building through a maintenance access window or maintenance door.

3.7 *Planter box*

3.7.1 The major M&R works for planter box include cleansing, irrigation and replacement of flower pots.

3.7.2 The M&R access to the outer surface of planter box shall be provided by maintenance access window, power-operated elevating work platform or suspended working platform.

3.8 *Projecting window*

3.8.1 The major M&R works for projecting window include inspection, cleansing of glass panels, and repair and replacement of defective window panes, window casements and sealant.

3.8.2 The M&R access to the outer surface of projecting window shall be provided by maintenance access window, power-operated elevating work platform or suspended working platform.

3.9 *Signboard*

3.9.1 The major M&R works for signboard include inspection, repair and replacement of the signboard and its components.

- 3.9.2 The M&R access for external signboard, other than access panel(s) mentioned in paragraph 3.9.3 below, shall be provided by fixed maintenance ladder or external walkway, maintenance staircase, maintenance access ladder and gantry system accessible from the interior of a building through maintenance access window or maintenance door, power-operated elevating work platform or suspended working platform.
- 3.9.3 Suitable inspection panel shall be provided for inspection of all the concealed fixings and structural members of a signboard unless they meet the criteria of relevant designated exempted works specified in Part 2 of Schedule 2 of the Building (Minor Works) Regulation (Cap. 123N). The side or diameter of the inspection panel shall be not less than 200 mm. The inspection panel shall be readily openable without the use of special tools or destructive means. For the avoidance of doubt, inspection panel is not required for a signboard with banner/vinyl display mounted on supporting frames of signboards which is readily removable to expose the concealed fixing.

3.10 *Sun-shade, reflector, eave, cornice, moulding, overhang, fin and other architectural projection*

- 3.10.1 The major M&R works for projections include inspection, repair and replacement of defective part.
- 3.10.2 The M&R access shall be provided by maintenance access window, power-operated elevating work platform or suspended working platform.

4. Roof

4.1 *Accessible roof*

- 4.1.1 Accessible roof of a building shall be provided with protective barrier at its outer edge in accordance with sections 37 and 38 of the Building (Construction) Regulation (Cap. 123Q) (B(C)R).
- 4.1.2 The major M&R works for an accessible roof include inspection, cleansing, repair, replacement of defective part of roof finishes, features, facilities (including solar energy system and building services) and signboards on the roof.
- 4.1.3 The M&R access shall be provided by direct staircase or maintenance door.
- 4.1.4 Fixed maintenance ladder or external walkway shall be provided for

signboards on roof if any part of the signboards is more than 5 m high measuring from the roof finishes.

4.2 *Inaccessible roof*

4.2.1 An inaccessible roof is not intended to be used for occupation and is accessible to personnel for M&R works only which include inspection, cleansing and repair and replacement of defective part of roof finishes, features, facilities (such as water tank, solar energy system and building services) and signboards on roof.

4.2.2 The M&R access shall be provided by fixed maintenance ladder or external walkway, maintenance access ladder and gantry system, maintenance door, power-operated elevating work platform or suspended working platform.

4.2.3 Where stepping onto the inaccessible roof for M&R works is required, safety measures such as guard-rails with toe-boards shall be provided at the edge of the roof in accordance with the requirements set out in paragraph 4 of *Appendix D*.

4.2.4 Fixed maintenance ladder or external walkway shall be provided for signboards on inaccessible roof if any part of the signboards is more than 5 m high measuring from the roof finishes.

5. *Projection from a Roof*

5.1 The M&R works for projection from a roof include inspection, cleansing, repair and replacement of defective part.

5.2 The M&R access shall be provided by fixed maintenance ladder or external walkway, maintenance access ladder and gantry system, maintenance staircase, power-operated elevating work platform or suspended working platform.

PART 3 - DESIGN AND CONSTRUCTION REQUIREMENTS

1. General Requirements

- 1.1. The M&R access shall be designed to cater for the operational need for M&R including material delivery. In case the M&R access is accessible from individual premises, suitable provision shall be provided in the Deed of Mutual Covenant (DMC) of the building to the effect that a reasonable right of access to the premises must be allowed for access by the maintenance personnel to the M&R access. Where no DMC is to be in force for the development, such right of M&R access shall be incorporated into the Sales and Purchase Agreement, Assignment or the Tenancy Agreement such that the future owners or tenants are aware of their rights and liabilities.
- 1.2. The M&R access shall be so provided to enable the workers to reach the intended external building elements within a hand-reachable range of not more than 500 mm in front of the element for carrying out M&R works. Attention shall be drawn to any building recess design that may hinder the M&R access.
- 1.3. In addition to the requirements in the Code, the M&R access shall comply with Part B and Part C of the Code of Practice for Fire Safety in Buildings (FS Code). The requirements for protective barriers under sections 36, 37 and 38 of the B(C)R, regulation 3A of the B(P)R, PNAP APP-110, and the Code of Practice for Dead and Imposed Loads 2011 (Loading Code) shall also be complied with as appropriate.
- 1.4. Where there is a risk of fall from a height of 2 m or more, guard-rails and toe-boards shall be provided to comply with the occupational safety requirements set out in paragraph 4(a) and (b) of *Appendix D* unless a protective barrier in accordance with sections 37 and 38 of the B(C)R is provided. Guard-rails should be of suitable and sound materials of sufficient strength and capacity, and should be designed to resist the imposed loads⁸ and wind loads⁹, where appropriate.

⁸ Guard-rails should be designed to resist the imposed loads under the category of “Area where congregation of people is not expected” as prescribed in Table 3.13 of the Loading Code.

⁹ If guard-rails should be subjected to wind loads, they should be designed to resist the more stringent requirement of either imposed load or the design wind loads as described in the Code of Practice on Wind Effects in Hong Kong.

- 1.5. Where anchorages for personal fall arresting system are required to be provided, the provision shall comply with the occupational safety requirements set out in paragraph 7 of *Appendix D*. For cast-in anchors, the structural details shall be submitted for approval under the BO.

2. Specific Requirements

2.1 *Suspended working platform*

- 2.1.1 Buildings shall be designed and constructed to take into account the provision of the suspended working platform serving its designed functions. All structural supporting frames, members and fixings for the platform including any screen shall be designed to withstand all combinations of loads imposed (including wind load) by the system and shall be subject to the approval under the BO. These structural elements shall either be corrosion resistant or protected with anti-corrosion system.
- 2.1.2 The platform shall be so located and provided not to obstruct the means of escape required under Part B of the FS Code. When the platform is not in operation, it shall be properly tied to the building to prevent undue movement.
- 2.1.3 Adequate restraints shall be provided strategically at the façade of a building which can be exposed to wind, to prevent undue tipping, tilting, swaying or horizontal movement of the platform in operation.
- 2.1.4 Suitable, adequate and safe access to the platform shall be provided. In case there is a risk of fall from a height of 2 m or more when the worker enters into the platform at height, one or more permanent cast-in anchors shall be provided on the roof for anchoring the personal fall arresting devices by each worker.
- 2.1.5 Where a temporary suspended working platform is proposed, mechanical booms or anchorages on the roof at suitable locations shall be provided to enable the installation of a temporary suspended working platform at a later stage. All associated structural members, fixings and anchorages of facilities shall either be corrosion resistant or protected with anti-corrosion system.

2.2 *Maintenance access window*

2.2.1 Access opening of a maintenance access window shall have a clearance of not less than 460 mm wide by 1100 mm high to enable the operation for M&R including material delivery. The sill of the window shall be at a height of not less than 1.1 m above the internal floor finished level of the adjoining floor. One or more permanent cast-in anchors shall be provided at the external wall for anchoring of the fall arresting devices by each worker before climbing out to the external.

2.2.2 The cast-in anchors shall be located at a position which is close to the maintenance access windows and readily accessible by the worker and at a height of not less than 1.5 m and not more than 1.8 m above floor finished level of the adjoining floor. The maintenance access window when opened shall not obstruct the worker from using the cast-in anchors.

2.3 *Maintenance staircase*

2.3.1 Maintenance staircase shall be of width not less than 900 mm to cater for workers holding equipment and materials for M&R, and it shall be provided with guard-rails on both sides complying with the occupational safety requirements set out in paragraph 4 of *Appendix D*.

2.4 *Maintenance door*

2.4.1 Maintenance door shall be of size not less than 600 mm wide by 2000 mm high. It shall be locked to avoid misuse and prevent unauthorised access. It shall also bear on the conspicuous part of its outside face a warning notice in English and Chinese in letters and characters not less than 25 mm high as follows :

DANGER

UNAUTHORISED ACCESS PROHIBITED

CLOSE AND LOCK THIS DOOR

危險

不得擅進

請關閉並緊鎖此門

2.5 *Fixed maintenance ladder or external walkway*

2.5.1 Fixed maintenance ladder shall be of width not less than 400 mm and not more than 600 mm with safety hoops of width not less than 650 mm and not more than 800 mm and comply with the occupational safety requirements set out in paragraph 8 of *Appendix D*. Where an opening to a slab is required for providing M&R access to certain area, the side or diameter of such opening shall be not less than 500 mm.

2.5.2 Fixed maintenance external walkway shall comply with the occupational safety requirements set out in paragraph 4 of *Appendix D*. The design of the walkway shall not obstruct M&R of external building elements. For a walkway to be erected over a roof or other projections, adequate working space of not less than 1.2 m high shall also be provided underneath the walkway for necessary M&R works.

2.6 *Maintenance access ladder and gantry system*

2.6.1 Maintenance access ladder and gantry system shall be designed to fit the building profile and the M&R works, and shall comply with the occupational safety requirements set out in paragraph 8 of *Appendix D*.

2.7 *Power-operated elevating work platform*

2.7.1 If an elevating work platform is proposed, the extent of the external walls to be accessed shall not exceed 1.5 m above the platform level when it is in the maximum operation height.

2.7.2 A levelled and firm designated area shall be provided in the development for parking the platform.

3. Checklist and Submission of M&R Access Plans

3.1 A checklist for provision of M&R access is provided in *Appendix E* for reference.

3.2 The procedures for submission of M&R access plans including details, information, supporting documents and developer or owner's letter of undertaking for compliance with the Code are provided in *Appendix F* for reference.

REFERENCE

For work safety in external building elements, reference may be made to:

Legislation

1. Buildings Ordinance, Cap. 123
2. Building (Construction) Regulation (Cap. 123Q)
3. Building (Minor Works) Regulation (Cap. 123N)
4. Factories and Industrial Undertakings Ordinance (Cap. 59) (Additional information in ***Appendix D***)
5. Construction Sites (Safety) Regulations (Cap. 59I) (Additional information in ***Appendix D***)
6. Factories and Industrial Undertakings (Suspended Working Platforms) Regulation (Cap. 59AC) (Additional information in ***Appendix D***)
7. Occupational Safety and Health Ordinance (Cap. 509) (Additional information in ***Appendix D***)
8. Occupational Safety and Health Regulation (Cap. 509A) (Additional information in ***Appendix D***)

Codes of Practice issued by Buildings Department

9. Code of Practice for Dead and Imposed Loads
10. Code of Practice for Fire Safety in Buildings
11. Code of Practice for Structural Use of Concrete
12. Code of Practice for Structural Use of Steel
13. Code of Practice on Wind Effects in Hong Kong

Codes of Practice and Guidance Notes issued by Labour Department

14. Code of Practice for Bamboo Scaffolding Safety
15. Code of Practice for Metal Scaffolding Safety
16. Code of Practice for Safe Use and Operation of Suspended Working Platforms
17. Guidance Notes on Classification and Use of Safety Belts and their Anchorage Systems
18. Guidance Notes on the Inspection, Thorough Examination and Testing of Suspended Working Platforms
19. Guidance Notes on Safe Use of Power-operated Elevating Work Platforms
20. Overview of Work-at-Height Safety

Practice Notes for Authorized Persons, Registered Structural Engineers and Registered Geotechnical Engineers (PNAP) issued by Buildings Department

21. PNAP APP-2, Calculation of Gross Floor Area and Non-accountable Gross Floor Area - Building (Planning) Regulation 23(3)(a) and (b)
22. PNAP APP-19, Projections in relation to Site Coverage and Plot Ratio - Building (Planning) Regulations 20 and 21
23. PNAP APP-53, Building (Construction) Regulation
24. PNAP APP-93, Planning and Design of Drainage Works
25. PNAP APP-110, Protective Barriers
26. PNAP APP-117, Structural Requirements for Alteration and Addition Works in Existing Buildings
27. PNAP APP-126, Erection of signboards
28. PNAP ADV-11, Suspended Working Platforms
29. PNAP ADV-33, Essential Information in Plan Submissions

Joint Practice Notes (JPN) issued by Buildings Department, Lands Department and Planning Department

30. JPN 1, Green and Innovative Buildings
31. JPN 2, Second Package of Incentives to Promote Green and Innovative Buildings

Relevant Guidelines and Publications

32. Guidelines on the Design and Construction of Bamboo Scaffolds, Buildings Department
33. General and Technical Guidelines on Minor Works Control System, Buildings Department
34. Guidelines on the Design, Installation and Maintenance of Cast-in Anchors at External Walls of New Buildings (Version 2), Construction Industry Council
35. Guidelines on Planking Arrangement for Providing Working Platforms on Bamboo Scaffolds (Version 2), Construction Industry Council
36. Pictorial Guide to Planning and Design for Safety, Hong Kong Housing Authority

REQUIREMENTS OF AIR-CONDITIONER (AC) PLATFORM COMBINED WITH BALCONY/UTILITY PLATFORM (UP)

An AC platform combined with a balcony and/or UP should satisfy the following criteria:

- (a) Its disposition should follow Figures B1, B2 or B3 below;
- (b) A minimum of 50 mm rise in level from the finished floor of the balcony/UP should be provided in the AC platform;
- (c) A working space for maintenance of the AC should be provided either in the front or at the back of the AC and with direct access from the balcony/UP;
- (d) The length and depth of the working space should be not less than the length of the AC platform and 400 mm respectively;
- (e) Its outer edges should be provided with protective barriers as required under sections 37 and 38 of the B(C)R;
- (f) Any screens provided to separate the AC platform from the balcony/UP should not be higher than 1.6 m and should have permeability¹ not less than 70 %;
- (g) Any screens provided at the edge of the platform should not be higher than the parapet level of the balcony and/or UP (1.6 m for platform with stacked ACs) and should have permeability not less than 70 %; and
- (h) For exclusion of the AC platform from gross floor area calculation, the connected balcony/UP should be subject to Joint Practice Notes No. 1 and No. 2 (JPN 1 and JPN 2)² and the following requirements are fulfilled –
 - (i) The area of each AC platform shown in Figures B1 to B3 below should be not more than 0.8m². Hence, the outer edges of the AC platform should not be included in the perimeter of the balcony/UP or the covered area under the lowest balcony/UP; and

¹ Permeability means the visual and physical porosity of the screens.

² In relation to the requirement of facing into the open air stipulated in the JPNs for balcony/UP, any balcony/UP combined with AC platform should use the perimeter of the merged floor for assessing compliance with the 40% requirement of facing into the open air. For the screen mentioned in paragraph (g) at the perimeter of the merged floor, it is not regarded as facing into the open air if it is higher than the parapet level of the balcony/UP.

- (ii) The letter of undertaking required under paragraph 2(a) of *Appendix A* of JPN 1 and JPN 2 should include the designation of the AC platforms as ‘areas for air-conditioning’ in the Deed of Mutual Covenant (DMC) with details of the use and location clearly indicated and a requirement that **individual AC platforms must not be erected at the external walls of the building**. Where no DMC is to be in force for the development, such designation and requirement shall be incorporated into the Sales and Purchase Agreement, Assignment or the Tenancy Agreement such that the future owners or tenants are aware of their rights and liabilities.

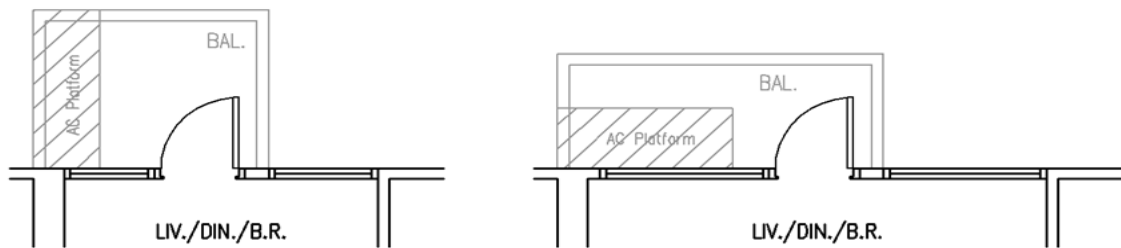

Figure B1: AC Platform in Balcony

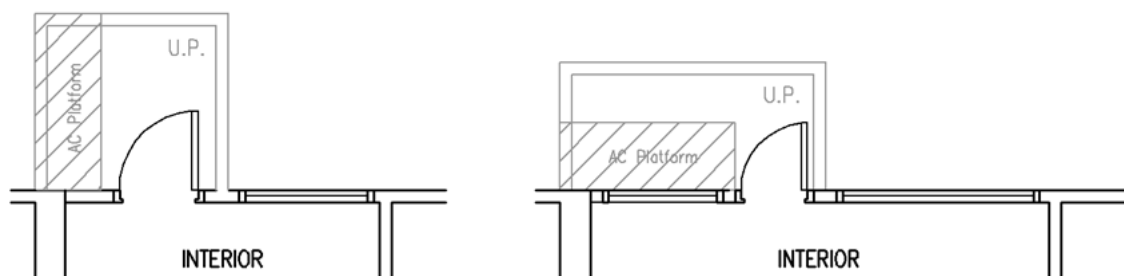
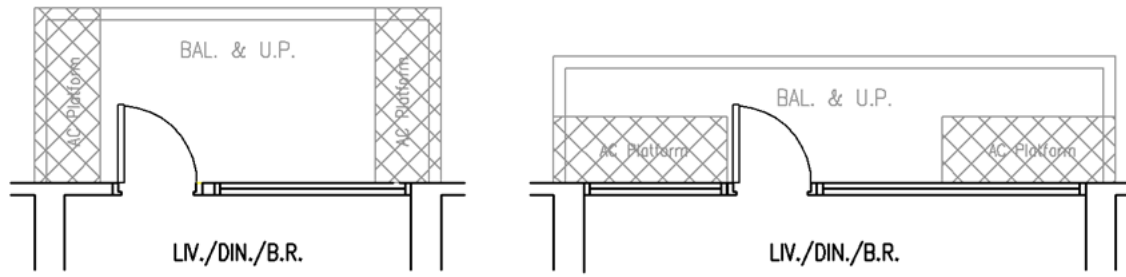

Figure B2: AC Platform in UP



**Figure B3: AC Platforms in combined Balcony and UP
(one AC platform is also acceptable)**

**REQUIREMENTS OF DESIGN AND SAFETY PROVISIONS
FOR THE AIR-CONDITIONER PLATFORM**

Access

1. The access openings shall normally have a clearance of not less than 460 mm by 1100 mm, and in no case less than the size of the air-conditioner (AC) to be installed. The bottom side of such openings shall be located not higher than 1300 mm from the finished floor level of the adjoining AC platform for the maintenance and repair (M&R) works.

Configuration of AC Platform

2. The size of the platform and the AC to be installed thereon shall be indicated on general building plans for assuring adequate working spaces provided for the M&R works for the AC. The optimum size of the platform is as follows:

(a) *Projection and Width*

The maximum projection of AC platform may be up to 900 mm disregarding the thickness of the protective barrier/guard-rail/screen including its supporting structural members. Width of the platform shall be restricted to housing the AC and providing working space for paragraphs 2(b) and 3 below, but not serving as catwalks.

(b) *Working Space*

The length and depth of the working space, either in front or at the back of the AC, should be not less than the length of the AC and 400 mm respectively. The length of the working space on one side of the AC should be not less than 400 mm which may be increased to a maximum of 500 mm if it also serves as the worker's landing through windows. Subject to the provision of screens at paragraph 5 or guard-rails at paragraph 6 below; and the provision of cast-in anchors at paragraph 6 below having been met, the working space in front or at the back of the AC may also serve as a maintenance passage to other AC and/or services and utilities provided in accordance with paragraph 3 below as appropriate. Minor encroachment onto the working space (e.g. supporting frame of the stacked up AC under paragraph 2(d) below, etc.) may be accepted.

(c) *Ventilation Gap*

A minimum gap of 100 mm between the AC and the outer edge of the platform (or inner side of screen if exists) or the external wall shall be provided.

(d) *Heights of AC and Screen*

To minimise the extent of the platforms, those with access in/from the units can be designed for stacking up of two ACs but the height of the screen, if any, shall be not more than 1.6 m. If one layer of AC is provided, the height of the screen shall be not less than 0.9 m and not more than 1.1 m.

3. Services and utilities not serving AC may be accepted to pass through the platform on which the AC is placed, provided that the working space required for M&R works will not be jeopardised. For example, vertical stack may pass through the AC platform not occupying the working space required; or the services may run horizontally at a level above the platform not jeopardising the safety nor compromising the working space.

Screens

4. Screens may be provided at a platform provided that they are:
 - (a) Maximum 50 mm thick,
 - (b) Not less than 70% permeability (i.e. the visual and physical porosity) from elevation,
 - (c) Constructed in panels with sizes and weight that are reasonably operable by a trade worker, and
 - (d) Able to withstand impact load¹ of the trade workers when carrying out the M&R works.
5. A screen fulfilling paragraphs 2(d) and 4 above may be accepted to serve as a guard-rail required under paragraph 6 below provided that the requirements stipulated therein are complied with. Such screen/guard-rail including its supporting structural members may be excluded from the measurement of the maximum projection of the AC platform.

¹ The impact load shall be designed to resist the minimum imposed loads under the category of “area where congregation of people is not expected” as prescribed in Table 3.13 of the Code of Practice for Dead and Imposed Loads.

Anchors and Guard-rails

6. Where access to an external wall is required, cast-in anchors and guard-rails shall be provided in accordance with the requirements set out in the Guidelines on the Design, Installation and Maintenance of Cast-in Anchors at External Walls of New Buildings (Version 2) issued by the Construction Industry Council. In addition, the design and location of the cast-in anchors and guard-rails shall be shown on the general building plans and structural plans for approval. The following general note shall also be added to the general building plans:

“Cast-in anchors and guard-rails at air conditioner platforms will be provided in accordance with the Code of Practice on Access for External Maintenance. Their structural details will be submitted separately for approval.”

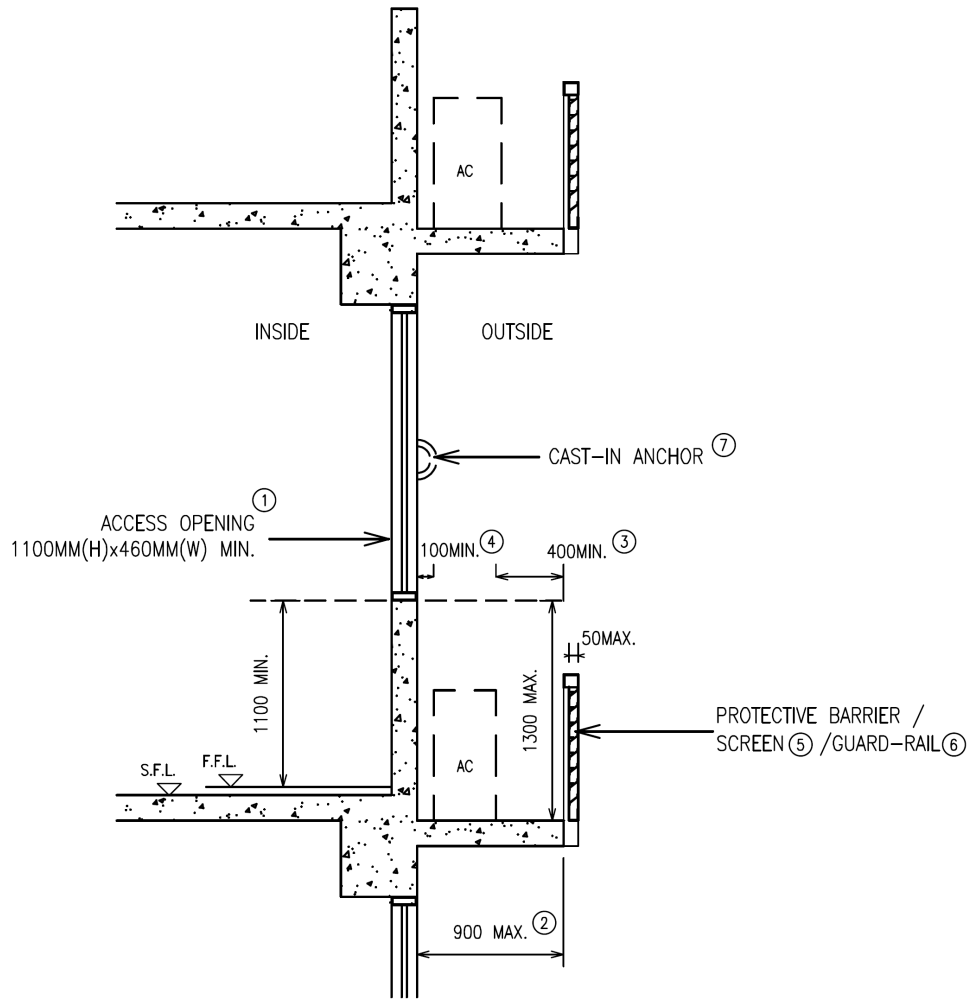

Figure C1: Section of AC Platform

LEGEND:

- ① ACCESS OPENING REFERS TO PARAGRAPH 1 .
- ② MAXIMUM PROJECTION REFERS TO PARAGRAPH 2(a).
- ③ WORKING SPACE REFERS TO PARAGRAPH 2(b).
- ④ VENTILATION GAP REFERS TO PARAGRAPH 2(c).
- ⑤ SCREEN REFERS TO PARAGRAPH 2(d), 4 AND 5.
- ⑥ GUARD-RAIL REFERS TO PARAGRAPH 6.
- ⑦ CAST-IN ANCHOR REFERS TO PARAGRAPH 6.

STATUTORY OCCUPATIONAL SAFETY REQUIREMENTS

If M&R works to external building elements fall under the ambit of occupational safety, such works shall fulfill the relevant requirements of the Occupational Safety and Health Ordinance (Cap. 509) (OSHO), Factories and Industrial Undertakings Ordinance (Cap. 59) (FIUO) and their subsidiary regulations so as to safeguard workers' safety at work. The legislation has stipulated the requirements for employers/occupiers of the premises/proprietors undertaking works-at-height (including works on external walls), including provision of suitable and adequate safe access to and egress from the workplace and taking adequate steps to prevent the fall of person. For carrying out building external M&R works, the Labour Department (LD) has also promulgated relevant codes of practice and guidance notes as shown in the *Appendix A* which help contractors and employers to understand and comply with the relevant legislative requirements.

2. Under section 6 of the OSHO and section 6A of the FIUO, every employer/proprietor of an industrial undertaking must, so far as is reasonably practicable, ensure the safety and health at work of all the employer's employees at the workplace and persons employed by the proprietor at the industrial undertaking. His duties include but not limited to:

- (a) provide and maintain plant and systems of work that are safe and without risks to health;
- (b) make arrangements for ensuring safety and absence of risks to health in connection with the use, handling, storage or transport of plant or substances;
- (c) provide information, instruction, training and supervision as may be necessary to ensure the safety and health at work of all person employed by him at the workplace/industrial undertaking;
- (d) maintain the workplace/industrial undertaking including the provision and maintenance of means of access to and egress from the workplace/industrial undertaking, in a condition that is safe and without risks to health; and
- (e) provide and maintain a working environment for all persons employed by him at the workplace/industrial undertaking that are, so far as is reasonably practicable, safe and without risks to health.

3. Under section 7 of the OSHO, if an employee's workplace is located on premises that are not under the control of the employee's employer, the occupier of the premises (such as the owner of the premises) must ensure that the premises and the means of access to and egress from the premises are, so far as reasonably practicable, safe and without the risks to health.

4. Where construction works (including M&R works) is undertaken and there is a risk of falling from a height of 2 m or more, the M&R access (e.g. gangways and runs), where appropriate, shall comply with the requirements as stipulated at the Third Schedule of the Construction Sites (Safety) Regulations (Cap. 59I), including the provision of:

- (a) Top guard-rail with a height of not less than 900 mm and not more than 1150 mm and intermediate guard-rail with a height of not less than 450 mm and not more than 600 mm;
- (b) Toe-board with a height of not less than 200 mm; and
- (c) Gangways and runs with a width of not less than 400 mm and for movement of materials with a width of not less than 650 mm so far as reasonably practicable.

5. Where the platform of M&R access in a workplace could be a danger to the safety of persons, under section 6 of the Occupational Safety and Health Regulation (Cap. 509A), the employers and the occupiers of the workplace where appropriate must ensure that the platform is securely fenced to a height of 900 mm. Where fencing is not reasonably practicable, effective personal fall protection system shall be provided.

6. Provision of safe and suitable working platform and access/egress for M&R works at the external wall shall be considered in the first place. Personal fall protection including the use of cast-in anchors shall only be treated as a supplementary safety measure or the last resort for protection of workers from falling from height.

7. Anchorages for personal fall arresting system shall comply with the requirements set out in the "Guidance Notes on Classification and Use of Safety Belts and their Anchorage Systems" published by LD and the "Guidelines on the Design, Installation and Maintenance of Cast-in Anchors at External Walls of New Buildings (Version 2)" published by the Construction Industry Council (CIC). An example of cast-in anchor extracted from the CIC's guidelines is given in *Appendix G*.

8. For a maintenance ladder having the distance between its highest point and the ground or floor is more than 3 m, anti-climbing device (e.g. ladder guards, ladder lock, etc.) at its lower level and suitable safety hoops shall be provided for prevention of unauthorised climbing. In addition, suitable landing/platform, which serves as a temporary rest place, shall be provided at an interval of not greater than 9m along the maintenance ladder. Such landing/platform shall be provided with suitable guard-rails and toe-board complying with paragraph 1.4 of Part 3 of the Code.

APPENDIX E

CHECKLIST FOR PROVISION OF MAINTENANCE AND REPAIR ACCESS

Means of Access Provided		External Building Elements (specify the location as appropriate)	
<input type="checkbox"/>	Suspended working platform	<input type="checkbox"/>	Air-conditioner platform
		<input type="checkbox"/>	Balcony and utility platform
		<input type="checkbox"/>	Canopy
		<input type="checkbox"/>	Cornice, eave, fin, moulding, overhang, reflector, sun-shade, and other architectural projections
		<input type="checkbox"/>	Curtain wall
		<input type="checkbox"/>	Drying rack
		<input type="checkbox"/>	External cladding
		<input type="checkbox"/>	External drainage pipe
		<input type="checkbox"/>	External vertical greenery
		<input type="checkbox"/>	External wall
		<input type="checkbox"/>	Inaccessible roof
		<input type="checkbox"/>	Planter box
		<input type="checkbox"/>	Projections from a roof
		<input type="checkbox"/>	Projecting window
<input type="checkbox"/>	Signboard		
<input type="checkbox"/>	Others (please specify)		
<input type="checkbox"/>	Maintenance access window	<input type="checkbox"/>	Air-conditioner platform
		<input type="checkbox"/>	Canopy
		<input type="checkbox"/>	Cornice, eave, fin, moulding, overhang, reflector, sun-shade, and other architectural projections
		<input type="checkbox"/>	Drying rack
		<input type="checkbox"/>	External drainage pipe
		<input type="checkbox"/>	External vertical greenery
		<input type="checkbox"/>	External wall
		<input type="checkbox"/>	Signboard
		<input type="checkbox"/>	Planter box
		<input type="checkbox"/>	Projecting window
<input type="checkbox"/>	Others (please specify)		
<input type="checkbox"/>	Maintenance staircase	<input type="checkbox"/>	Projections from a roof

Means of Access Provided		External Building Elements (specify the location as appropriate)	
		<input type="checkbox"/>	Signboard
		<input type="checkbox"/>	Others (please specify)
<input type="checkbox"/>	Maintenance door	<input type="checkbox"/>	External vertical greenery
		<input type="checkbox"/>	Inaccessible roof
		<input type="checkbox"/>	Signboard
		<input type="checkbox"/>	Others (please specify)
<input type="checkbox"/>	Fixed maintenance ladder or external walkway	<input type="checkbox"/>	External drainage pipe
		<input type="checkbox"/>	External vertical greenery
		<input type="checkbox"/>	Inaccessible roof
		<input type="checkbox"/>	Projections from a roof
		<input type="checkbox"/>	Signboard
		<input type="checkbox"/>	Others (please specify)
<input type="checkbox"/>	Maintenance access ladder and gantry system	<input type="checkbox"/>	Inaccessible roof
		<input type="checkbox"/>	Projections from a roof
		<input type="checkbox"/>	Signboard
		<input type="checkbox"/>	Others (please specify)
<input type="checkbox"/>	Power-operated elevating work platform	<input type="checkbox"/>	Air-conditioner platform
		<input type="checkbox"/>	Balcony and utility platform
		<input type="checkbox"/>	Canopy
		<input type="checkbox"/>	Cornice, eave, fin, moulding, overhang, reflector, sun-shade, and other architectural projections
		<input type="checkbox"/>	Curtain wall
		<input type="checkbox"/>	Drying rack
		<input type="checkbox"/>	External cladding
		<input type="checkbox"/>	External drainage pipe
		<input type="checkbox"/>	External vertical greenery
		<input type="checkbox"/>	External wall
		<input type="checkbox"/>	Inaccessible roof
		<input type="checkbox"/>	Planter box
		<input type="checkbox"/>	Projections from a roof
		<input type="checkbox"/>	Projecting window
		<input type="checkbox"/>	Signboard
		<input type="checkbox"/>	Others (please specify)

**PROCEDURES FOR SUBMISSION OF
MAINTENANCE AND REPAIR ACCESS PLANS
FOR COMPLIANCE WITH
CODE OF PRACTICE ON ACCESS FOR EXTERNAL MAINTENANCE**

Maintenance and Repair Access Plans

To demonstrate compliance with the requirements set out in the Code, the following information on the M&R access should be provided for consideration:

- (a) Plans, elevations and sections at a legible ratio (preferably not less than 1:300) showing the location and the design of the proposed M&R access to the external building elements at each floor/zone on a building basis.
- (b) Technical specification demonstrating the adequacy of the proposed M&R access to the intended areas (e.g. technical specification showing the length of the cradle and tie-back restraints for suspended working platforms, etc.).
- (c) A summary of the proposed M&R access with reference to Appendix E of the Code.

2. It is possible that the design for M&R access to the facades of a building may not have been finalised when the general building plans (GBP) are first submitted. Hence, for developments adopting the requirements of the Code, information of M&R access (i.e. M&R access plans) needs not be provided in the first GBP submission. However, a note stating that “Before applying for the consent to commence the superstructure works, the provisions for M&R access required under the Code of Practice on Access for External Maintenance will be submitted to and approved by BD.” should be indicated in the GBP.

3. Structural details in respect of M&R access (e.g. cast-in anchors, restraint sockets, mechanical booms or anchorages for the temporary suspended working platform, etc.) should be submitted separately for approval. For cast-in anchors, they should be installed at pre-determined locations at the external reinforced concrete walls with a minimum thickness of 125mm or the external structural elements of a building.

If drill-in anchors for anchoring the fall arrest devices are proposed for alteration and addition (A&A) works to an existing building, an assessment¹ on the structural viability of the works should be submitted together with the structural plans.

4. The following details, information and supporting documents should be included in the structural plans submitted for approval under the Buildings Ordinance:

- (a) structural framing, details, sections and/or elevations of structural elements;
- (b) design loads;
- (c) anchors and support details;
- (d) design standards and codes of practice;
- (e) material specifications for structural steel, aluminum alloy, cast-in anchors, drill-in anchors, fixing screws/bolts, proprietary products, etc. if applicable;
- (f) workmanship specifications for welding, galvanisation, measures to overcome bi-metallic effects and durability requirement with corrosion prevention; and
- (g) structural calculations comprising design check on the parent structure² sustaining the loads of the M&R access, analysis on the structural adequacy and stability of the proposed structures for M&R access, element design for structural steel, aluminum or metal grating and deflection check on major load carrying members, if applicable.

Letter of Undertaking

5. A letter should be submitted by the developer or owner undertaking to designate the M&R access as ‘common areas’ in the DMC with details of the use and

¹ For A&A works in existing buildings, reference should be made to PNAP APP-117.

² Parent structures include newly constructed reinforced concrete or steel structural elements and existing structures. For structural requirements for A&A works in existing buildings, reference should be made to PNAP APP-117.

location clearly indicated together with the submission of GBP with the provisions for M&R access³. In case the M&R access is accessible from individual premises, a provision shall be provided in the DMC to the effect that a reasonable right of access to the premises must be allowed by the maintenance personnel to the M&R access. Where no DMC is to be in force for a development, designation of the M&R access and the access route to and egress from such for communal use and the right of M&R access should be incorporated into the Sales and Purchase Agreement, Assignment or the Tenancy Agreement.

Submission of Record Plans

7. In addition to the requirements stipulated under PNAP APP-13, an additional set of record plans related to the M&R access is required to be submitted upon application for an occupation permit or submission of certificate of completion for the A&A works⁴ (Form BA14) for referral to the Labour Department for their use.

³ Mandatory for new buildings only.

⁴ In case M&R access is proposed for A&A works to an existing building.

EXAMPLE OF CAST-IN ANCHOR

(Extracted from the “Guidelines on the Design, Installation and Maintenance of Cast-in Anchors at External Walls of New Buildings (Version 2)” issued by the Construction Industry Council)

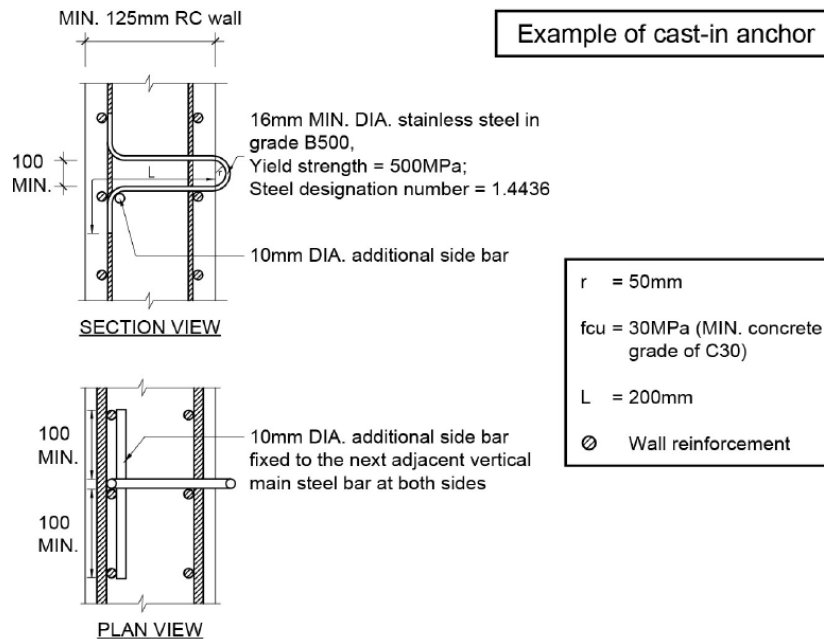

Cast-in anchors should be positioned at the external reinforced concrete (RC) walls with a minimum thickness of 125 mm or external structural elements of all new buildings in such a way that they are safely accessible and easily visible to workers when carrying out external repair and maintenance of existing buildings. They should in no case make the workers exposed to the risk of falling in the course of securing and detaching the anchorage.

The design life of the cast-in anchors should be the same as the design life of the building, and should be taken into consideration in the design of the anchors.

The cast-in anchors should be installed at pre-determined locations before casting of the supporting structural elements. The anchor bars should be of stainless steel in Grade B500 complying with BS 6744:2016 and designation number 1.4436 or of equivalent standard with a minimum diameter of 16 mm or be designed to sustain the load test as required for Type A anchor device in BS EN 795:2012. Designers may make reference to “Structural Design of Stainless Steel” – SCI publication P291 by N.R. Baddoo and B.A. Burgan (Published by The Steel Construction Institute), Concrete Society Technical Report 51 “Guidance on the Use of Stainless Steel Reinforcement” (Published by Concrete Society (UK)), BS 6744:2016 “Stainless steel bars – Reinforcement of concrete – Requirements and test methods”, etc.